

Concept[®] - H – PENDULUM SYSTEM

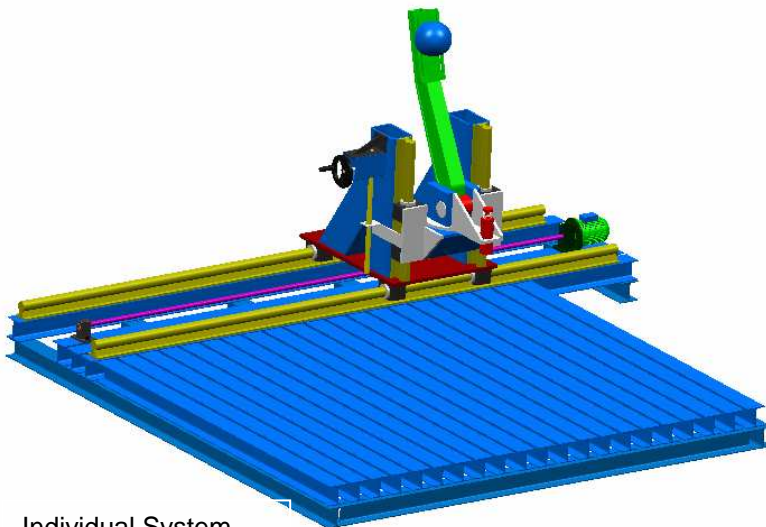

Individual System

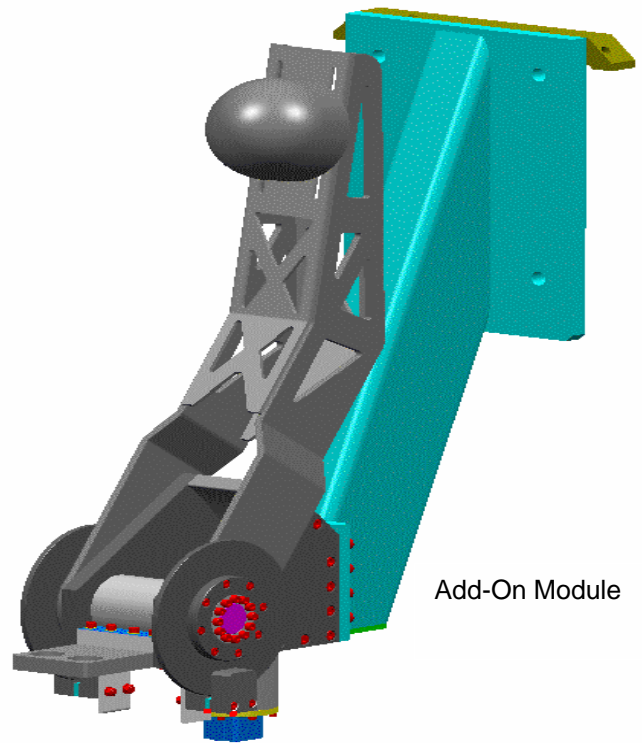

Add-On Module

Functional Description

This Concept developed test system is used as an aid during the developing and optimizing of the instrument panel or similar energy absorbing elements in the cockpit area according to ECE- R21.

The measured acceleration of the impactor allows conclusions to be drawn regarding the components and body force.

Hereby the effectiveness of further developments for the relevant areas becomes cost-effective.

The pendulum is available as an individual or as an add-on module (e.g. FMH system).

Due to this unique solution, with the special Concept developed rotary piston gear, reproducible realistic tests are possible!

FROM USER TO USER

As a user and system developer, we offer our customers our know-how.

Benefits at a Glance:

- ✓ Reproducible measuring results (repeat precision $\pm 0,2$ km/h) due to the contactless rotary piston
- ✓ Many variable tests are made possible (continuous variable impact energies) via pressure adjustability
- ✓ Highly flexible due to the being able to use the system individually
- ✓ Large cost savings due to the „comparison matrix“ and thereby avoiding comparison tests
- ✓ Simple adjustment to the test points due to the compact construction and 4 axes movement
- ✓ Due to automatic brake assembly, no secondary impact is possible

Concept® - H – PENDULUM SYSTEM



www.concept-tech.com

Technical Data:

- Work and Control Medium: Nitrogen
- Supply Pressure: 10 bar
- Test Speed: 8 up to 28 km/h adjustable
- Repeat Precision: $\pm 0,2$ km/h
- Test Specimen Weight: $6,8 \pm 0,5$ kg

System Description:

- 1 Retainer mechanism for simple assembly on Concept's FMH system
- 1 Piezo- Accelerometer
- 1 Rotary encoder for angle measurement
- 1 Proportional valve for speed adjustability (continuous) via pressure adjustment
- 1 Rotary piston ensures a force free conducted impact
- 1 Remote control for continuous easy adjustment (770-910 mm)

System Measurements (Module):

Total Length: ca. 910 mm
 Total Width: ca. 600 mm
 Total Height: ca. 1.100 mm

Pendulum height above ground: 900 up to 1800 mm

- Impact Angle: 75-190° Forceless Guidance
- Total Weight: ca. 200 kg (Module weight)
- Control System: SPS Siemens S7
- E- Connection Power: ca. 0,3 kW

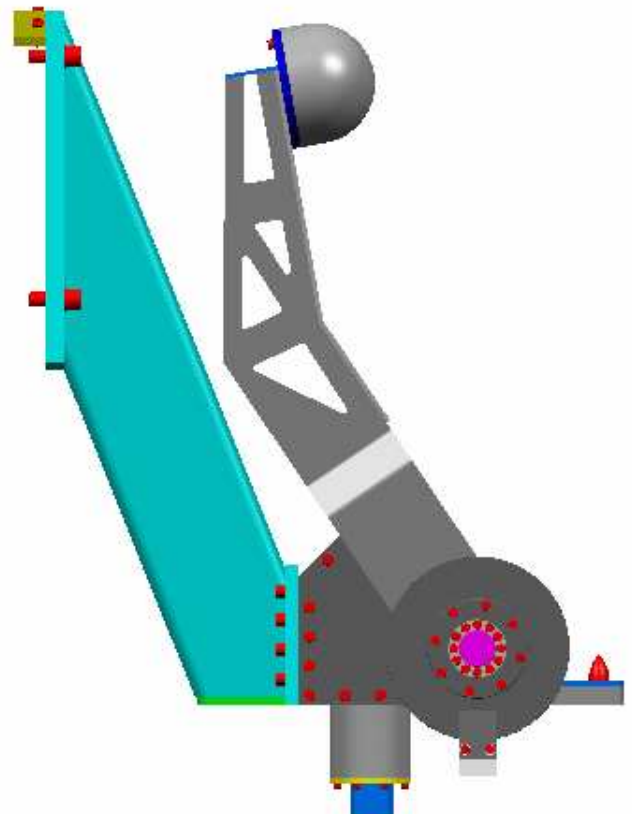

Test Data Bank:

The test data bank is used for the consolidation and management of the following data:

- Measuring data (launch force, speed, position of the system)
- Crash data (high-speed video, acceleration curves, DAT-files, sensors used, impact location, pictures)
- Test setup with component management
- Possibility of combining project related analysis data and tests

✓ The Concept test data bank can be individually customized.

